

SOUTH ATLANTIC

GALVANIZING



WE'VE GOT YOU COVERED

10 Plants located strategically across the Southeast

www.southatlanticllc.com

How to Mark Your Items for Identification



Remember the most important considerations in identification markings:

- 1) The identification must be made so as to be legible after galvanizing.
- 2) The markings must not disrupt the integrity of the zinc coating and compromise the rustproofing.

For example: Oil-based paints, oil-based markers, or crayon markers will not come off in the cleaning solution used to prepare items for galvanizing. These types of markings may create ungalvanized areas.

For temporary identification, use water-soluble markers or detachable metal tags.

For permanent identification, there are three methods that enable items to be rapidly identified at the job site after galvanizing:

1) Stamp the surface

Create identification marks by using die-cut deep stencils or by making a series of center punch-

STAMPED/WELDED TAG SEAL-WELDED



marks. These marks should be placed in a standard position on each of the items, preferably toward the center.

The marking must be a minimum of 1/2" (13 mm) high and 1/32" (.8 mm) deep to ensure readability after galvanizing.

Important: Do not use this method to mark fracture-critical members.

2) Use a series of weld beads

Letters or numbers can be made directly on the items using this method.

Important: All welding flux must be removed after welding or it will interfere with proper galvanizing.

3) Attach deep-stenciled steel tags

Tags should be wired loosely to the items so that the area beneath the wire will not freeze to the items when the molten zinc solidifies. Or, if you prefer, tags may be seal-welded directly to the materials.

Important: Tags must be a minimum of #12 gauge, and the attaching wire must be a minimum of #9 gauge steel wire.

To find out more about Kettle Tags, and other ways we make hot-dip galvanizing easier for our customers, call 910-332-1900.



Arkansas

Little Rock Area



KETTLE SIZE: 45' long x 5.25' wide x 9.5' deep
MAXIMUM CRANE CAPACITY: 15 tons

South Atlantic Galvanizing
1710 E. 145th St.
Little Rock, AR 72206
Phone: (Toll Free) 888. 307.2595
Local: 501.580.5325



Two Methods for Fabricating Handrails for Galvanizing



Figure 1

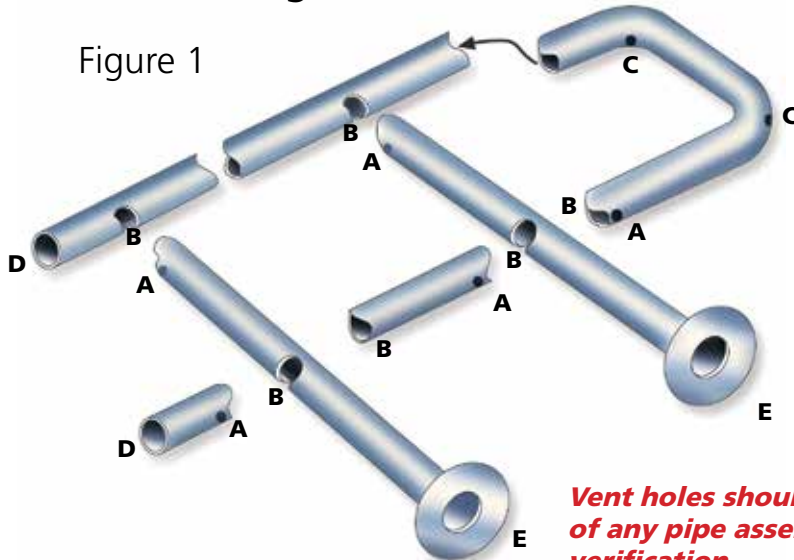

Vent holes should be visible on the outside of any pipe assembly to provide internal vent verification.

1. If full internal holes are incorporated into the design (Best method)

- A. External vent holes must be as close to the weld as possible and a minimum of 3/8" (9.5 mm) in diameter. **NOTE: Most pipe rails are 1 1/4" or 1 1/2" pipe which require minimum 9/16" vent holes.**
- B. For the best galvanizing quality and the lowest cost, internal holes should be the full I.D. of the pipe.
- C. Vent holes in end sections or in similar sections must be 1/2" (13 mm) in diameter.
- D and E. Ends should be left completely open. Any device used for erection in the field that prevents full openings on ends of horizontal rails and vertical legs should be galvanized separately and attached after galvanizing.

2. If full internal holes are NOT incorporated into the design (Alternative method)

Figure 2

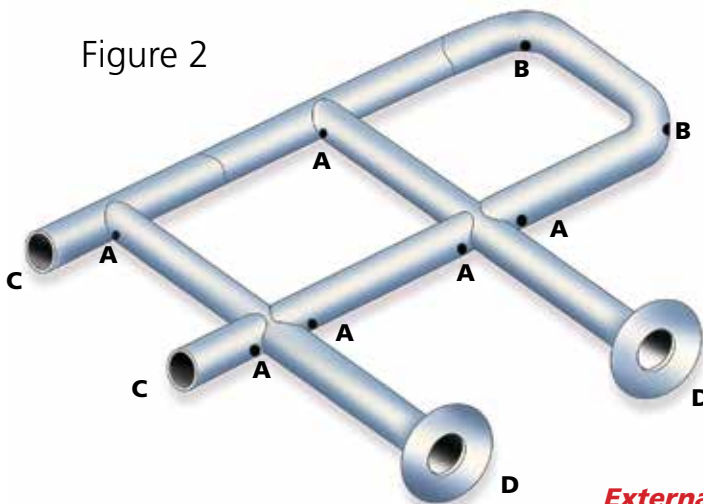

A. Each external vent must be as close to the welds as possible and must be 25% of the I.D. of the pipe but not less than 3/8" (9.5 mm) in diameter. The two holes at each end and at each intersection must be 180° apart and in the proper location.

B. Vent holes in end sections or in similar sections must be 1/2" (13 mm) in diameter.

C and D. Ends should be left completely open. Any device used for erection in the field that prevents full openings on ends of horizontal rails and vertical legs should be galvanized separately and attached after galvanizing.

External vent holes should be visible on the outside of pipe assemblies.



Louisiana

Baton Rouge Area



KETTLE SIZE: 58' long x 7.0' wide x 8.0' deep
MAXIMUM CRANE CAPACITY: 10 tons



South Atlantic Galvanizing
19550 Salvant Road
Zachary, LA 70791
Phone: (Toll Free) 800.376.4419
Local: 225.654.7005
Fax: 225.658.7607



How to Fabricate Trusses for Galvanizing

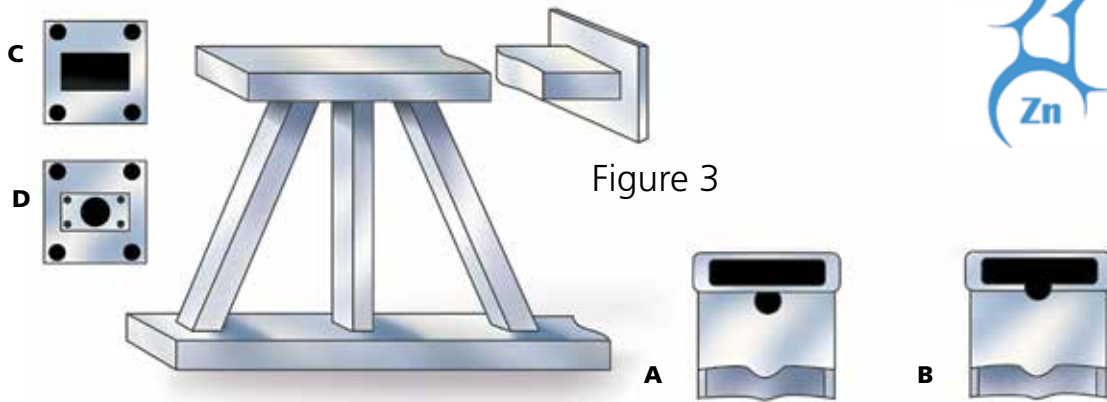

Figure 3

Rectangular Tube Trusses

Vertical Sections

Hole locations for vertical members should be placed as shown in examples A and B on Figure 3.

Each vertical member should have two holes at each end, 180° apart and in line with the horizontal members. It is best if the holes are of equal size, and the combined area of the two holes at either end of the verticals should be at least 30% of the cross-sectional area.

Horizontal End Plates

Preferably, the fabrication is completely open. (See example C on Figure 3.)

- If $H + W = 24''$ (61 cm) or larger, the area of the hole (plus clips) should equal 25% of the area of the tube ($H \times W$).
- If $H + W =$ less than 24'' (61 cm) but more than 16'' (41 cm), the area of the hole (plus clips) should equal 30% of the area of the tube ($H \times W$).
- If $H + W =$ less than 16'' (41 cm) but more than 8'' (20 cm), the area of the hole (plus clips) should equal 40% of the area of the tube ($H \times W$).
- If $H+W =$ less than 8'', leave it open **See Figure 6 on page 10.**

Pipe Trusses 3'' (7.6 cm) or larger

Vertical Sections

Hole locations for vertical members should be placed as shown in examples A and B on Figure 4.

Each vertical member should have two holes at each end, 180° apart and in line with the horizontal members as indicated by the arrows. It is best if the holes are of equal size, and the combined area of the two holes at either end of the verticals (Areas C and D or Areas E and F) should be at least 30% of the cross-sectional area.

Horizontal End Plates

Preferably, the fabrication is completely open with the same hole diameter as the inner diameter of the tube. (See example G on Figure 4.)

Alternatives would have openings at least 30% of the area of the inside diameter. (See examples H, I, and J on Figure 4.)

Figure 4

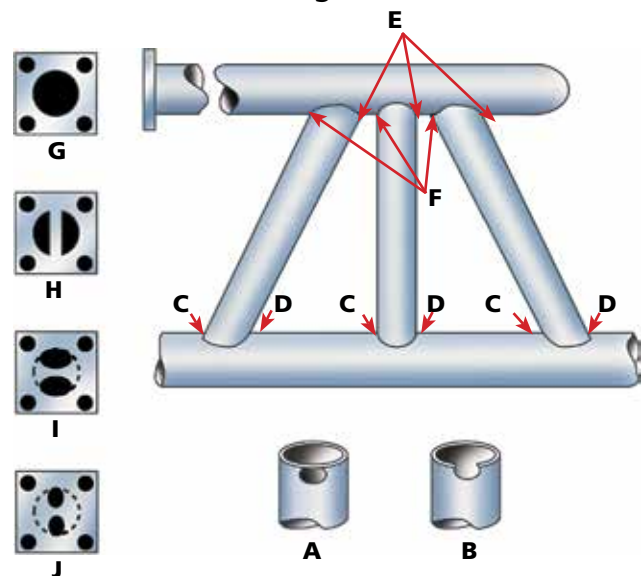



North Carolina

Greensboro/Burlington Area



KETTLE SIZE: 51' long x 5' wide x 10' deep
MAXIMUM CRANE CAPACITY: 10 tons

South Atlantic Galvanizing
P.O. Box 1380
3025 Steel Way Drive & Highway 54
Buckner Industrial Park
Graham, NC 27253
Phone: (Toll Free) 800.438.7010
Local: 336.376.0410
Fax: 336.376.9333



How to Fabricate Pipe Columns, Pipe Girders, Street Lights, and Transmission Poles for Galvanizing

(With base-plates and with or without cap-plates)

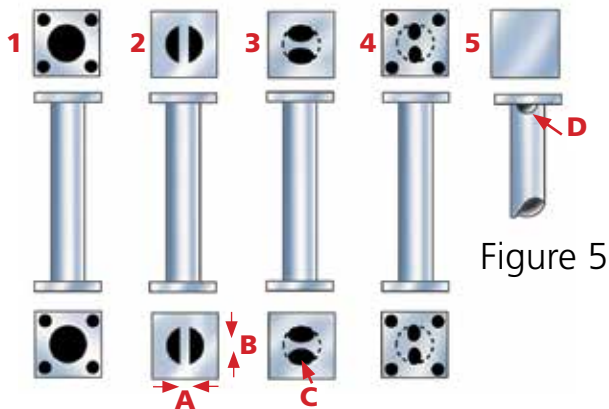

Figure 5



Location of openings:

1. The best design of fabrication is to have the end completely open with the same diameter as the section top and bottom.
- 2, 3, and 4. This is an acceptable substitute if it is not possible to have a full opening.
5. When no holes are allowed in the cap- or base-plate, two half-circles 180° apart at opposite ends of the pole must be used.

Dimensions:

Openings at each end must be at least 30% of the I.D. area of the pipe for pipes 3" (7.6 cm) and greater, and 45% of the I.D. area for pipes smaller than 3".

Allow 30% of the area of the I.D. for hole sizes at each end.

1. End completely open
2. Slot A = 3/4" (19 mm), Center hole B = 3" (7.6 cm) in diameter
3. An example of sizes for a 6" (15 cm) diameter section.
Half-circle C = 1.75" (4.5 cm) radius
4. Oval opening = 1.75" (4.5 cm) radius
5. Half-circle D = 1 5/8" (1.9 cm) radius

Figure 6

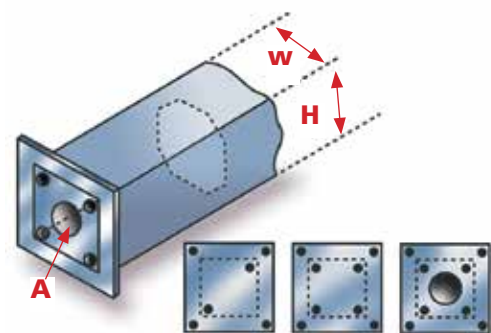

How to Fabricate Box Sections for Galvanizing

Holes and clipped corners must be flush as shown. Using the following formulas, the table shows typical sizes of holes:

- **Internal gussets:** Space at a minimum of 36" (91 cm).
- **Box sections:** When $H + W = 24"$ (61 cm) or larger, the area of the hole (plus clips) should equal 25% of the cross-sectional area of the box ($H \times W$).

When $H + W =$ less than 24" (61 cm) but greater than 16" (40.6 cm), the area of the hole (plus clips) should equal 30% of the cross-sectional area of the box ($H \times W$).

When $H + W =$ less than 16" (40.6 cm) but equal to or greater than 8" (20 cm), the area of the hole (plus clips) should equal 40% of the cross-sectional area of the box ($H \times W$).

When $H + W =$ less than 8" (20 cm), leave completely open with no end-plate or internal gusset.

The table is for square box sections only. For rectangular sections, calculate the required area, and check with South Atlantic for position of openings.

Box Size (H+W)	Holes A-Dia.
48" (122 cm)	8" (20 cm)
36" (91 cm)	6" (15 cm)
32" (81.3 cm)	6" (15 cm)
28" (71 cm)	6" (15 cm)
24" (61 cm)	5" (12.7 cm)
20" (50.8 cm)	4" (10.2 cm)
16" (40.6 cm)	4" (10.2 cm)
12" (30.5 cm)	3" (7.6 cm)



Virginia

Ashland/Richmond Area



KETTLE SIZE: 42' long x 5.5' wide x 8'5" deep
MAXIMUM CRANE CAPACITY: 10 tons

South Atlantic Galvanizing
P.O. Box 1420
11022 Lewistown Drive
Ashland, VA 23005
Phone: (Toll Free) 800.964.0097
Local: 804.798.3257
Fax: 804.798.4450



Venting



The primary reason for vent and drain holes is to allow air to be evacuated, permitting the object to be completely immersed into cleaning solutions and molten zinc. Proper sizing and location make it safer to galvanize and provide the optimal finish. The secondary reason is to prevent damage to the parts. Any pickling solutions or rinse waters that might be trapped in a blind or closed joining connection will be converted to superheated steam or gas and can develop a pressure of up to 3600 psi (1100 MPa) when immersed in molten zinc. Not only is there risk of damage to the fabrication being galvanized, but there also is risk of serious hazard to galvanizing personnel and equipment.

Cleaning solutions and molten zinc must be allowed to flow in and completely wet the surfaces. Proper galvanizing results when the inside and outside of a product are completely cleaned and zinc-coated.

Because items to be galvanized are immersed and withdrawn at an angle, the vent holes should be located at the highest point and drain holes at the lowest.

All sections of fabricated pipe-work should be interconnected with full open-tee or miter joints. Each enclosed section must be provided with a vent hole at each end.

Base-plates and end-plates must be designed to facilitate venting and draining. Fully cutting the plate provides minimum obstruction to a full, free flow into and out of the pipe. Since this is not always possible, using vent holes in the plate often provides the solution.

Vent holes are frequently left open but can be closed with drive caps or plugs after galvanizing.

Strengthening Gussets and Webs

Welded strengthening gussets and webs on columns and beams, and strengthening gussets in members fabricated from channel sections, should have corners cropped or holed:

- Prevents entrapment of air in pockets and corners allowing complete access of pickle acids and molten zinc to all surfaces
- Facilitates drainage during withdrawal from acid and rinse tanks, and the galvanizing bath

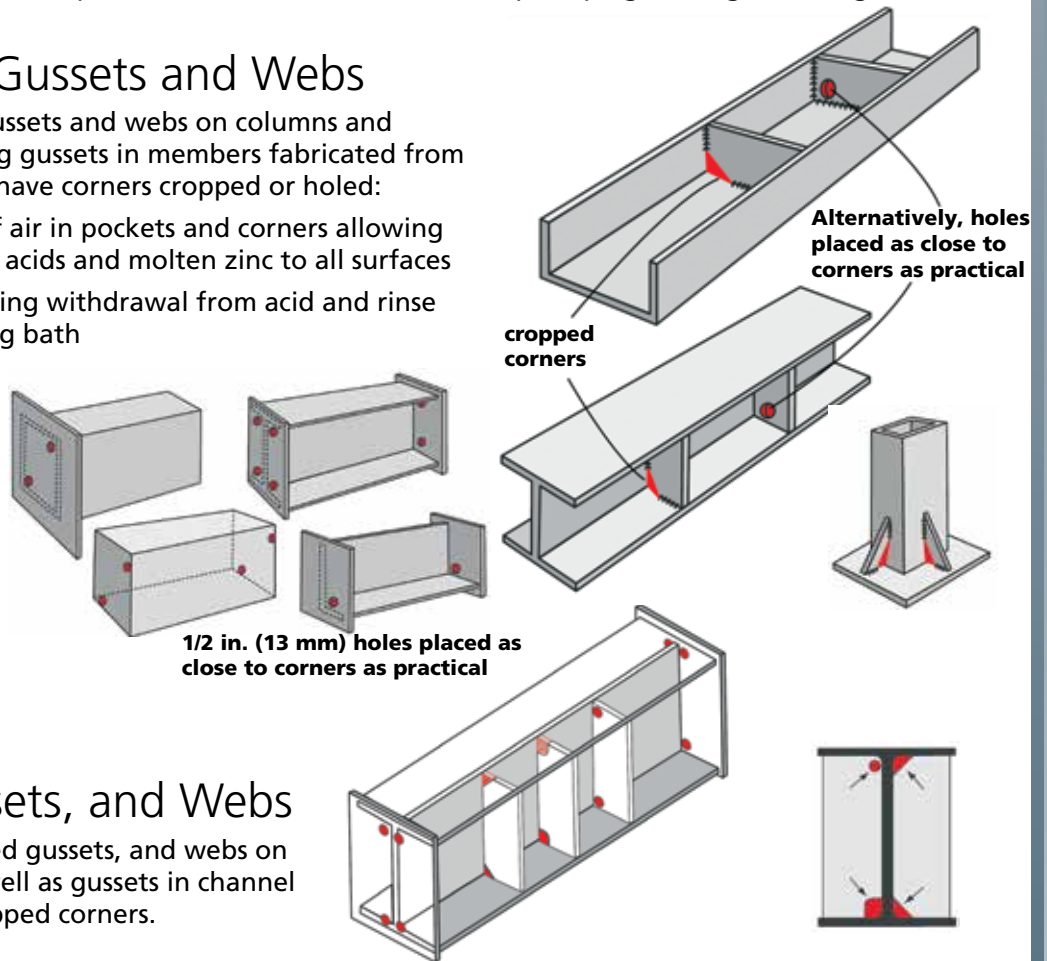

End Plates

Provide holes at least 1/2 in. (13 mm) diameter in end plates on rolled steel shapes to allow access and drainage of molten zinc.

Stiffeners, Gussets, and Webs

External stiffeners, welded gussets, and webs on columns and beams, as well as gussets in channel sections should have cropped corners.

Welding



Seal-Welding vs. Skip-Welding (See ASTM A385)

When welding prior to galvanizing, it is preferable to use uncoated electrodes and to seal-weld whenever possible. Perfect seal welds prevent cleaning solutions from being trapped between steel surfaces, where they may be converted to steam at galvanizing temperatures, possibly building up explosive pressures between the contacting steel. Any exhaustion of steam out of holes in the weld may prevent the galvanized coating from forming in the weld areas.

Due to zinc's relatively high viscosity, if skip-welding is used, the gap between steel surfaces must be >3/32 in. (2.4 mm). This permits cleaning solutions and molten zinc to penetrate all areas, delivering high-quality galvanized coatings. If a lesser gap is used, the zinc does not coat the surfaces behind the weld; trapped, less viscous pickling salts will eventually react with moisture and iron in the steel creating iron oxide that seeps out, staining the galvanized surface.

Larger Overlapping Surfaces

If contacting surfaces cannot be avoided, areas less than 16 in² (100 cm²) may be fully seal welded. For areas larger than 16 in² (100 cm²), refer to the table below for requirements.

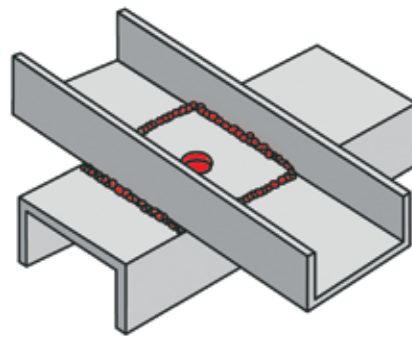

Welding Flux Resides **must**

be removed by wire brushing, chipping, grinding, pneumatic needle, or abrasive blast cleaning.

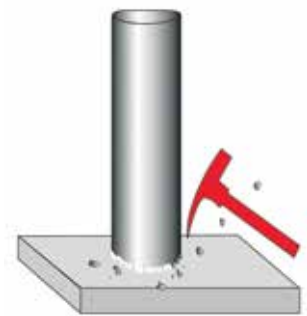

Overlapped Area in ² (cm ²)	VENT HOLES FOR OVERLAPPED AREAS FOR STEELS <1/2 IN. (12.75 MM) THICK		VENT HOLES FOR OVERLAPPED AREAS FOR STEELS >1/2 IN. (12.75 MM) THICK	
	Vent Holes	Unwelded Area	Vent Holes	Unwelded Area
under 16 (103)	None	None	None	None
16 (103) to under 64 (413)	One 3/8 in (1 cm)	1 in (2.5 cm)	None	None
64 (413) to under 400 (2580)	One 1/2 in (1.25 cm)	2 in (5.1 cm)	One 1/2 in (1.25 cm)	2 in (5.1 cm)
400 (2580) and greater, each 400 (2580)	One 3/4 in (1.91 cm)	4 in (10.2 cm)	One 3/4 in (1.91 cm)	4 in (10.2 cm)



South Carolina Greenville Area



KETTLE SIZE: 28' long x 4' wide x 6.5' deep
MAXIMUM CRANE CAPACITY: 6 tons

South Atlantic Galvanizing
P.O. Box 1042
US Highway 276 West
Travelers Rest, SC 29690
Phone: (Toll Free) 800.562.9377
Local: 864.834.3367
Fax: 864.834.7923



HOW LONG WILL GALVANIZED COATINGS LAST?

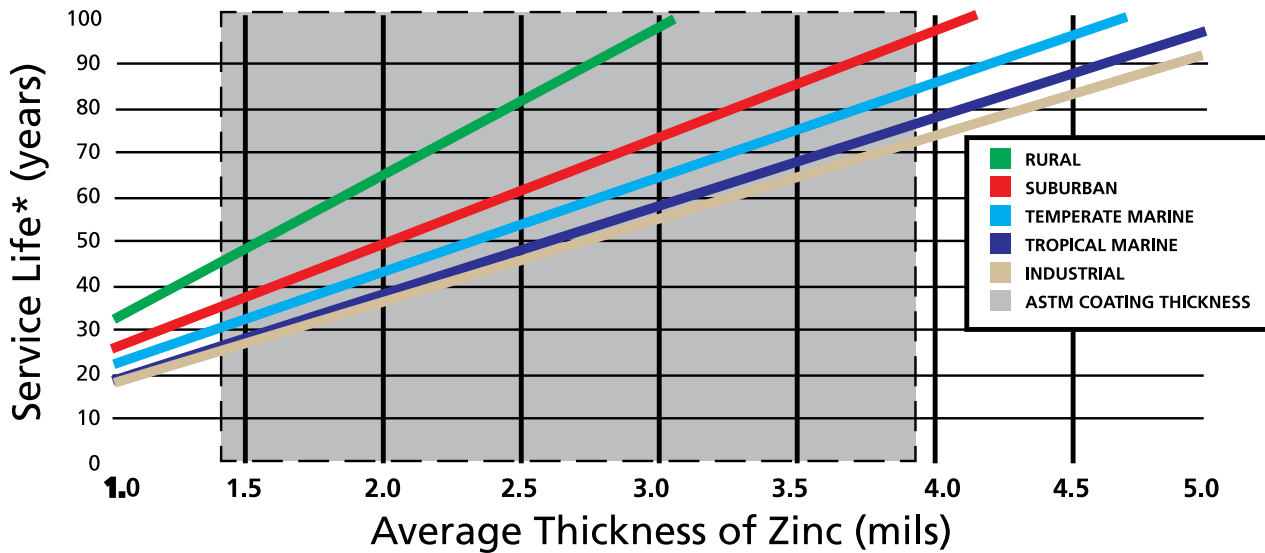

Service-life Details

Galvanizing is the choice for corrosion protection because the stable, non-reactive zinc patina that develops after several months of atmospheric exposure provides a coating that delivers maintenance-free performance for decades. With a corrosion rather 1/10 to 1/30 that of ungalvanized still (as determined by ASTM in-field studies since the 1920s), depending on the environment (industrial-most aggressive, to rural-least aggressive), the thicker the zinc coating, the longer lasting the corrosion protection. Variables in the environment that determine the service-life (corrosion rate) include the following:

- chlorides
- humidity
- rainfall
- salinity
- sulfur dioxide
- temperature

Example:

A structure comprised of 1/4" (6.4 mm) thick steel and galvanized to ASTM A 123 with a minimum of 3.9 mils (99 microns) of zinc, located in industrial Bethlehem, PA, where the average rainfall is 37" (94 cm), salinity is 3 mg/m², sulfur dioxide is 25 mg/m², and the relative humidity is 68%, will not need any maintenance for 82 years.

Galvanized containers also are widely used for long-term liquid and chemical storage, ranging for alcohols and hydrocarbons to penals and esters. Other common uses for galvanized steel include structure and facilities in fresh water and salt water. Agitation, chloride content and temperature are important variable in determining service-life in liquids, chemicals, and water.





Florida

Lakeland/Mulberry Area



KETTLE SIZE: 45' long x 5.25' wide x 9.5' deep
MAXIMUM CRANE CAPACITY: 10 tons

South Atlantic Galvanizing
P.O. Box 1057
3094 County Road 640 West
Mulberry, Florida 33860
Phone: (Toll Free) 855.451.3708
Local: 863.428.2050
Fax: 863.428.0150

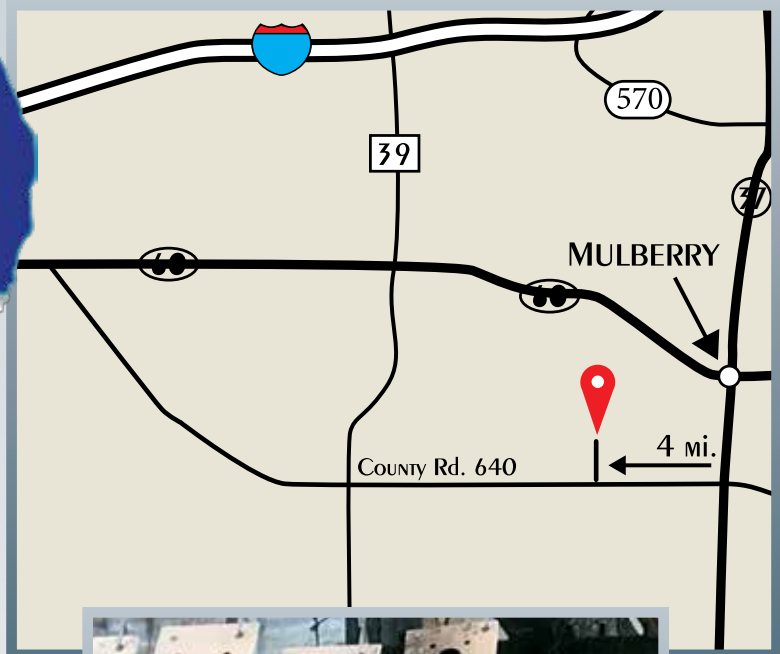

Performance Notes



Special Handling

- The zinc-iron alloy layers of the hot-dip galvanized (HDG) steel coating are harder than steel and are unaffected by rough handling typical during shipment and erection. Banding of HDG steel pieces in contact with each other is common and acceptable.
- There are significant material and labor costs associated with packaging painted structural steel or steel assemblies for shipping, including wood dunnage and soft material (paper, cardboard) interleave to prevent contact between individual pieces.

Field Touch-up

- Rarely needed for HDG steel unless for cosmetic reasons to hide a chain mark or to provide corrosion protection to a field-modified area.
- There is usually a time-consuming inspection and field touch-up necessary to repair damaged areas of painted bare steel.

Application

- Galvanizing is always factory-controlled, with a precise, scientific methodology that ensures complete coverage and corrosion protection.
- Whether the application of paint is done in the factory or field, the internal tubular sections and hard-to-reach areas of bare steel remain unprotected; these areas are where corrosion usually begins.

Weather Dependent

- Hot-dip galvanizing can be done any day of the year, the process totally independent of weather conditions.
- Painted systems often experience project delays because of unpredictable weather. When the parameters of safe and quality painting (temperature, humidity, wind) are stretched or compromised, coating failure is almost assured.

Temperature Range

- HDG steel provides superior corrosion protection when in service in a range of temperatures, from -75 F to 392 F.
- Most paints perform poorly in temperatures greater than 200 F.

Corrosion Protection

- Hot-dip galvanizing provides both cathodic and barrier protection to steel, delivering a rust- and maintenance-free system in most environments for 75 years or more.
- Paint is a barrier protector only, and when scratches and cracks occur, corrosion of the underlying steel is immediate.

Coating Thickness

- The metallurgical reaction between 840 F molten zinc and iron in steel ensure a uniform and guaranteed coating thickness, documented in ASTM specifications.
- Paint coating thickness on all surfaces is as variable and uniform as the applicator, with corners and edges highly susceptible to corrosion because of thin films.

Bond Strength

- The alloying of zinc and iron in the HDG coating means the zinc and steel metallurgically become one, yielding a coating bond ten times greater than the strictly mechanical bond of paint to steel.

Hardness/Abrasion Resistance

- With a coating hardness greater than that of steel alone, galvanized steel provides a durable, scratch-resistant coating that maintains the integrity of overall corrosion protection system.
- Paints are generally not resistant to scratching, cracking, or impact, resulting in a compromised coating where corrosion begins and maintenance painting is required.

Hot-Dip Galvanized Steel vs. Paint

	HDG Steel	Vs.	Paint	
	No	Special Handling	Paper interleave, cloth strips, wood separators	
	No	Field Touch-Up	Required	
	Factory	Application	Field or Factory	
	No	Weather Dependent	Yes	
	-75F to 392F	Temperature Range	< 200F	
	Cathodic & Barrier	Corrosion Protection	Barrier	
	> 3.9 Mills (1/4" thick steel)	Coating Thickness	Variable	
	3600 psi	Bond Strength	300-600 psi	
	179 to 250 DPN	Hardness/Abrasion Resistance	Varies by Type	
	75 Years	Service Life - Atmospheric	12-15 Years	

Metroflina Greenhouses Galvanized in 1971

Painted Parking Garage Stairs after 8 years of service



Georgia

Savannah Area



KETTLE SIZE: 28' long x 4' wide x 9' deep
MAXIMUM CRANE CAPACITY: 6 tons

South Atlantic Galvanizing
P.O. Box 876
Highway 280 West
Evans County Industrial Park
Claxton, GA 30417
Phone: (Toll Free) 800.782.3972
Local: 912.739.3238
Fax: 912.739.4829

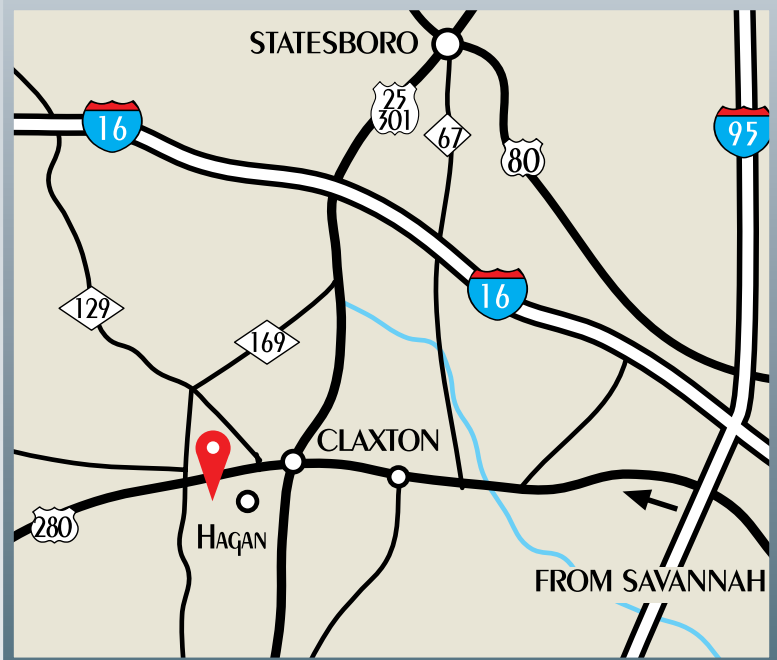



South Carolina

Laurens Area



KETTLE SIZE: 51' long x 6.5' wide x 10' deep
MAXIMUM CRANE CAPACITY: 15 tons

South Atlantic Galvanizing
P.O. Box 1559
5132 Metric Rd.
Laurens, S.C. 29360
Phone (Toll Free) 800.385.1593
Local: 864.682.5832

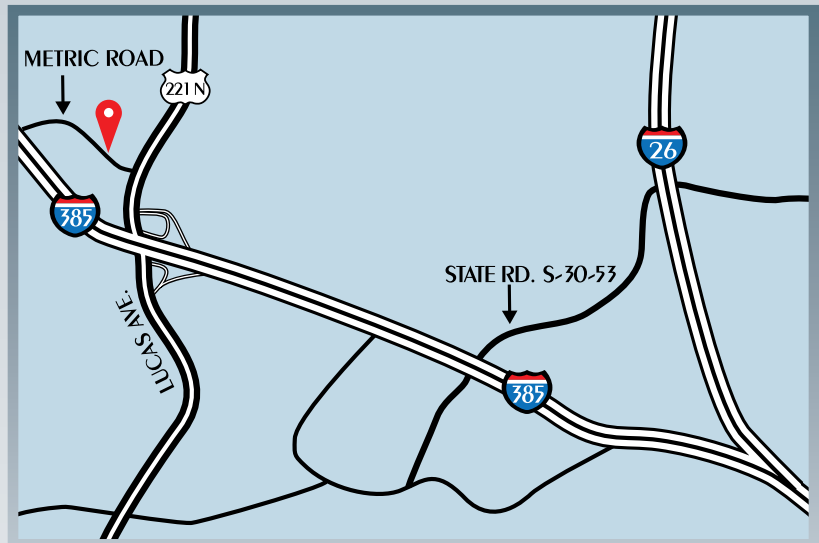



Mississippi

Tupelo Area



KETTLE SIZE: 58' long x 7.5' wide x 9' 5" deep
MAXIMUM CRANE CAPACITY: 20 tons

South Atlantic Galvanizing
61 County Road 520
Shannon, MS 38868
Phone: (Toll Free) 866.888.9193
Local: 662.601.4108
Fax: 662.608.6763



Ten plants located strategically ensure fast, on-time service with unequalled quality.

SHANNON, MISSISSIPPI

(Tupelo Area)
61 County Road 520
Shannon, MS 38868
Phone: (Toll Free) 866.888.9193
Local: 662.601.4108

GRAHAM, NORTH CAROLINA

(Greensboro/Burlington Area)
P.O. Box 1380
3025 Steel Way Drive & Highway 54
Buckner Industrial Park
Graham, NC 27253
Phone: (Toll Free) 800.438.7010
Local: 336.376.0410

ASHLAND, VIRGINIA

(Richmond Area)
11022 Lewistown Drive
Ashland, VA 23005
Phone: (Toll Free) 800.964.0097
Local: 804.798.3257

CHATTANOOGA, TENNESSEE

4186 South Creek Road East
Chattanooga, TN 37406
Phone: (Toll Free) 800.770.2031
Local: 423.698.2451

MULBERRY, FLORIDA

(Lakeland Area)
3094 County Road 640 West
P.O. Box 1057
Mulberry, Florida 33860
Phone: (Toll Free) 855.451.3708
Local: 863.428.2050

CLAXTON, GEORGIA

(Savannah Area)
160 Industrial Pk Dr • Hwy 280 West
Evans County Industrial Park
Claxton, GA 30417
Phone: (Toll Free) 800.782.3972
Local: 912.739.3238

LITTLE ROCK, ARKANSAS

1710 E. 145th St.
Little Rock, AR 72206
Phone: (Toll Free) 888.307.2595
Local: 501.580.5325

LAURENS, SOUTH CAROLINA

P.O. Box 1559
5132 Metric Rd.
Laurens, S.C. 29360
Phone (Toll Free) 800.385.1593
Local: 864.682.5832

TRAVELERS REST, SOUTH CAROLINA

(Greenville Area)
1006 Greer Hwy • US Hwy 276 West
Travelers Rest, SC 29690
Phone: (Toll Free) 800.562.9377
Local: 864.834.3367

ZACHARY, LOUISIANA

(Baton Rouge Area)
19550 Salvant Road
Zachary, LA 70791
Phone: (Toll Free) 800.376.4419
Local: 225.654.7005

Scan for more information on South Atlantic Galvanizing.



Other products of South Atlantic, LLC:



South Atlantic Galvanized Steel

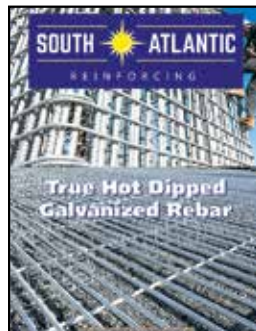

South Atlantic Reinforcing



Southern Grounding Products

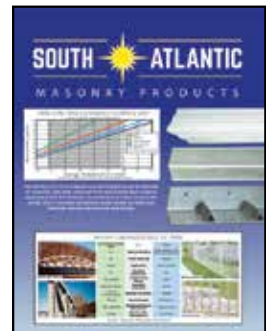

South Atlantic Masonry Products



Visit us on the Internet at www.southatlanticllc.com

